

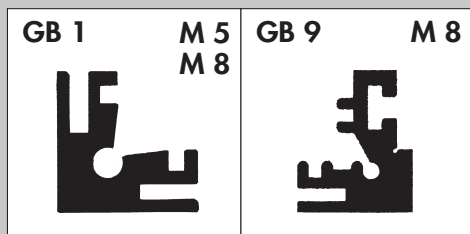





















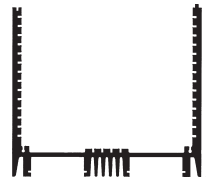













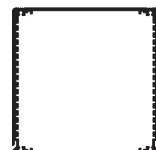
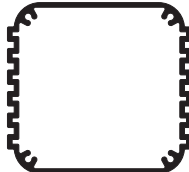
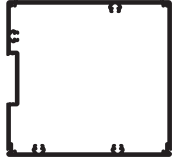

Rohový profily





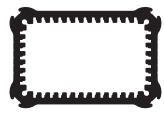
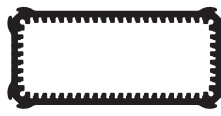

Kombinovatelné profily

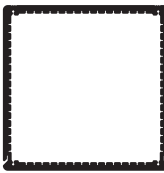
KOH 0 M 13 M 46 	KOH 1 M 13 M 46 	KOH 2 M 13 M 46 	KOH 4A M 13 M 46 	KOH 6 M 14 M 46 	KOH 7 M 14 
KOH 8 M 14 M 46 	KOH 10 M 14 M 46 	KOH 14 M 14 M 46 	KOP 2 M 13 	KOE 14 M 14 	KOE 2 M 13 
KOT 2 M 13 	KON 2 M 13 	KOK 14 M 15 	KOL 1 M 15 	KOL 2 M 15 	KOW 2 M 15 
KOK 2 M 13 	KOHL 0 M 16 	KOHL 1 M 16 	KOHL 2 M 16 	KOHL 4 M 16 	KOHL 6 M 16
KOHL 10 M 16 	KOHL 14 M 17 	KOLL 2 M 17 	KOTL 2 M 17 	KOR 2 M 13 	KOG 5 M 14 
KOF 3 M 14 					



Tubusové profily

TUG 03 M 23 	TUG 05 M 23 M 47 	TUG 09 M 23 	TUG 17 M 23 M 47 	GP 211 M 20 	GB 50 M 19 
GP 213 M 21 M 43 	GP 217 M 21 M 43 	GP 214 M 21 M 43 	GP 216 M 22 M 43 	GP 215 M 22 M 43 	GP 218 M 21 M 43 
GP 219 M 21 M 43 	GP 220 M 21 M 43 	GB 87 M 25 M 42 	GB 88 M 25 M 42 	TUG V 09 M 24 	TUG V 17 M 24 







Profily pro skřínky s zasunovatelným krycím plechem

GB 81 M 6 	GB 82 M 6 	GB 83 M 6 	GB 84 M 6 
--	--	--	---











Skřínky Design „Frame“ s integrovanými chladiči profily

GB 89 M 44 	GB 90 M 44 	GB 91 M 44 
---	---	---



Profily bočních stěn

GB 36 M 9 	GB 38 M 9 	GB 76 M 7 M 45 	GB 77 M 7 M 45 	GB 78 M 7 M 45 	GB 79 M 7 M 45 
G 118 M 35 					







Profily nosných rámců konstrukčních skupin

GB 29 N 15 N 30 N 74 	GB 30 N 15 N 30 N 74 	GB 31 N 74 	GB 32 N 74 	GB 33 N 74 	GB 34 N 74 
GB 5 N 74 	GB 20 N 74 	GB 27 N 75 	GB 35 N 15 N 73 	GB 37 N 75 	





Profily dílčích čelních panelů

GL 7 N 60 N 76 	GB 14 N 76 
--	---

Profily pro 19" zásuvné jednotky

GB 18 N 6 N 71 	GB 19 N 6 N 71 	GB 21 N 71 	GB 22 N 8 N 71 	GB 23 N 8 N 10 N 71 	GB 52 M 4 
--	--	---	--	--	--





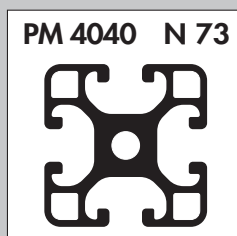

Profily pro 19" čelní panely

<p>GB 28 N 7 N 10 N 72</p> 	<p>GB 40 N 7 N 72</p> 	<p>GB 41 N 7 N 72</p> 	<p>GB 54 N 7 N 72</p> 	<p>GB 55 N 7 N 72</p> 
--	---	---	---	---



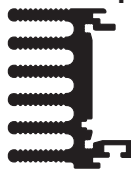
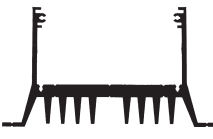











Profily pro konstrukci strojů



Profily pro skříňky s chladičnými žebry

<p>GB 56 M 32</p> 	<p>KRH 6 M 36</p> 	<p>KOS 5 M 36</p> 	<p>GB 53 M 37 N 73</p> 	<p>SK 61 M 34</p> 
<p>SK LED 1 M 38</p> 	<p>SK LED 2 M 38</p> 	<p>SK LED 3 M 38</p> 		

Profily pro zásuvné kazety

<p>GP 190 N 39 N 77</p> 	<p>GP 191 N 36 N 77</p> 	<p>GP 192 N 36 N 37 N 77</p> 	<p>GP 193 N 37 N 38 N 77</p> 	<p>GP 195 N 41 N 42 N 80</p> 	<p>GP 196 N 41 N 80</p> 
<p>GP 197 N 42 N 43 N 80</p> 	<p>GP 199 N 48 N 76</p> 	<p>GP 200 N 38 N 78</p> 	<p>GP 201 N 38 N 78</p> 	<p>GP 202 N 38 N 78</p> 	<p>GP 206 N 40 N 79</p> 
<p>GP 207 N 40 N 79</p> 	<p>GP 208 N 40 N 79</p> 	<p>GP 209 N 40 N 79</p> 